

WL50 Work Light

General-Purpose LED Work Lights

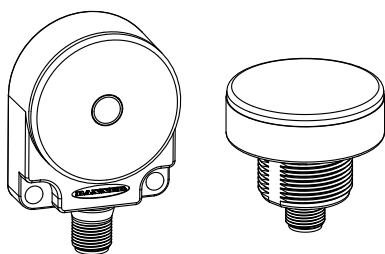

Shown are flat-mount model with push-button (left) and 30 mm base-mount model without

- Designed for enclosure or area lighting
- Illuminates a large area with an even pattern of light and no shadows
- Standard or push-button models available
- Flat-mount or 30 mm base-mount models available
- Rugged, sealed polycarbonate housing rated to IP69K (standard models) or IP67 (push-button models)
- Low-profile design with several mounting options
- 12 to 30V dc operation
- Cabled and quick-disconnect models available
- Low power consumption; less than 2 watts

Models

Flat-mount models include a 48 mm (1.9 in) circular velcro mounting kit for easy mounting with no additional hardware.

Model ¹	Push-Button	Mounting Style	Input
WL50F	Standard (no push-button)	Flat-mount	12 to 30V dc
WL50		30 mm base-mount	
WL50FPB	Push-button	Flat-mount	
WL50PB		30 mm base-mount	



WARNING: Not To Be Used for Personnel Protection

Never use this device as a sensing device for personnel protection. Doing so could lead to serious injury or death. This device does NOT include the self-checking redundant circuitry necessary to allow its use in personnel safety applications. A sensor failure or malfunction can cause either an energized or de-energized sensor output condition.

Specifications

Supply Voltage and Current

- 12 to 30V dc (10% max. ripple)
- Use only with suitable Class 2 power supply.
- Max. current: 105 mA @ 12V dc; 55 mA @ 30V dc
- Max. Input Power: 1.7 watts

Power-Up Response Time

- Light On: 1 ms (max.) for models without push-button

Light Characteristics

- Color temperature (CCT): 5000 to 10000 K
- Color: Cool white
- Intensity (typical): 65 lumens; 50 lux @ 1 meter

Construction

- Polycarbonate housing; nickel-plated QD connector or PVC-jacketed cable

Environmental Rating

- Standard models: IP69K per DIN 40050
- Push-Button Models: IEC IP67

Connections

- Integral 4-pin Euro-style QD, 150 mm PVC pigtail with QD, or 2 m 6.5' integral cable, depending on model

Operating Conditions

- 40° to +50° C (-40° to +122° F)

Certifications



Application Note

- Push-button models: When power is initially applied to the device, or following a power interruption and the light is off, push the push-button to turn the light on.

¹ Only standard 2 m (6.5 ft) cable models are listed. For 9 m (30 ft) cable: add suffix "W30" to the model number (e.g., WL50F W30). For 4-Pin Euro-style Integral QD connector, add suffix "Q" to the model number (e.g., WL50FQ). For 150 mm (6 in) 4-pin Euro pigtail QD, add suffix "QP" to the model number (e.g., WL50FQP). A model with a QD requires a mating cordset (see [Cordsets](#) on page 3).



Dimensions — Flat-mount

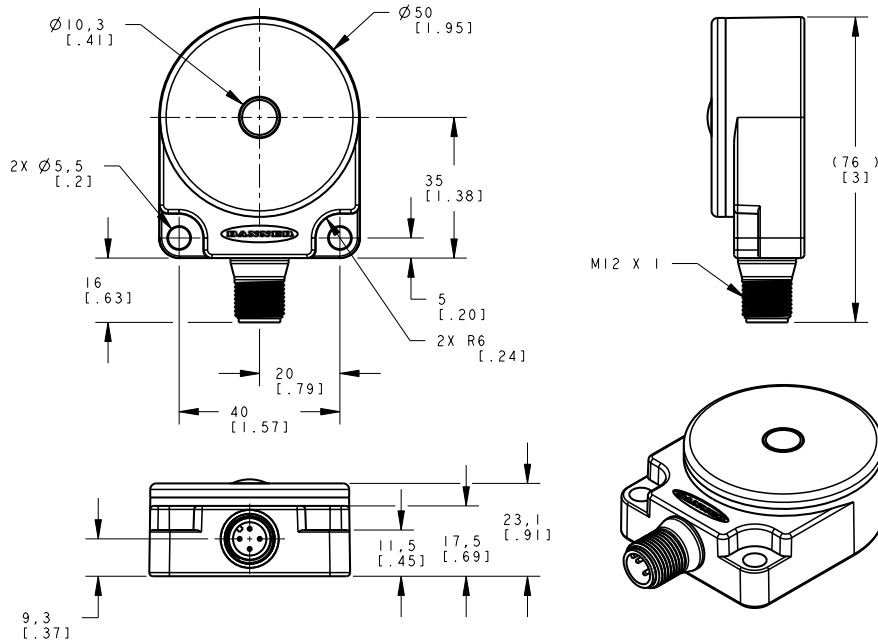

* Push-button model shown. Push-button located in center of light.

Dimensions — 30 mm base-mount

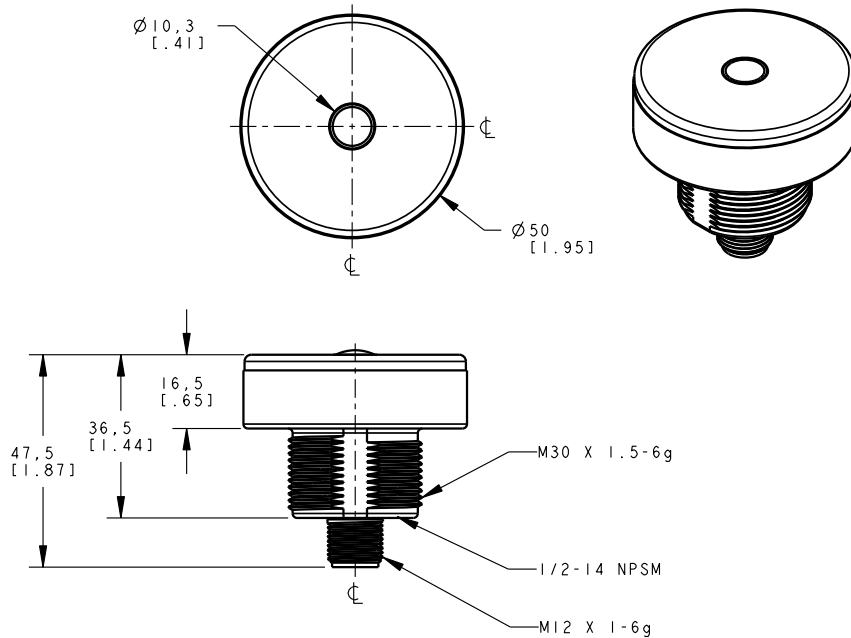

* Push-button model shown. Push-button located in center of light.

Wiring

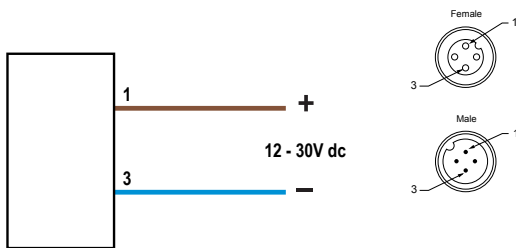

Wiring Key:

- 1 = Brown
- 3 = Blue

Cordsets

4-Pin Threaded M12/Euro-Style Cordsets				
Model	Length	Style	Dimensions	Pinout
MQDC-406	1.83 m (6 ft)	Straight		
MQDC-415	4.57 m (15 ft)			
MQDC-430	9.14 m (30 ft)			
MQDC-450	15.2 m (50 ft)			
MQDC-406RA	1.83 m (6 ft)	Right-Angle		1 = Brown 2 = White 3 = Blue 4 = Black
MQDC-415RA	4.57 m (15 ft)			
MQDC-430RA	9.14 m (30 ft)			
MQDC-450RA	15.2 m (50 ft)			

Banner Engineering Corp Limited Warranty

Banner Engineering Corp. warrants its products to be free from defects in material and workmanship for one year following the date of shipment. Banner Engineering Corp. will repair or replace, free of charge, any product of its manufacture which, at the time it is returned to the factory, is found to have been defective during the warranty period. This warranty does not cover damage or liability for misuse, abuse, or the improper application or installation of the Banner product.

THIS LIMITED WARRANTY IS EXCLUSIVE AND IN LIEU OF ALL OTHER WARRANTIES WHETHER EXPRESS OR IMPLIED (INCLUDING, WITHOUT LIMITATION, ANY WARRANTY OF MERCHANTABILITY OR FITNESS FOR A PARTICULAR PURPOSE), AND WHETHER ARISING UNDER COURSE OF PERFORMANCE, COURSE OF DEALING OR TRADE USAGE.

This Warranty is exclusive and limited to repair or, at the discretion of Banner Engineering Corp., replacement. **IN NO EVENT SHALL BANNER ENGINEERING CORP. BE LIABLE TO BUYER OR ANY OTHER PERSON OR ENTITY FOR ANY EXTRA COSTS, EXPENSES, LOSSES, LOSS OF PROFITS, OR ANY INCIDENTAL, CONSEQUENTIAL OR SPECIAL DAMAGES RESULTING FROM ANY PRODUCT DEFECT OR FROM THE USE OR INABILITY TO USE THE PRODUCT, WHETHER ARISING IN CONTRACT OR WARRANTY, STATUTE, TORT, STRICT LIABILITY, NEGLIGENCE, OR OTHERWISE.**

Banner Engineering Corp. reserves the right to change, modify or improve the design of the product without assuming any obligations or liabilities relating to any product previously manufactured by Banner Engineering Corp.